

VE1-1800 rpm Electric Vibrator

The POWTEK VE1-18 electric vibrator combines the simplicity of single phase power usage with the high amplitude of an 1800 vibrator.

It is ideal for applications where a deeper vibration is needed. Typical applications are usually small tables, little screens and chutes with material particles size ranging from 1/8" to 3/4"

It is supplied with a 4' cable and a starting capacitor. A control box with magnetic overload protection and ON/OFF switch can be supplied upon request



Single-Phase 1800 RPM

PERFORMANCE DATA

MODEL	FORCE OUTPUT		UNBALANCE	HP		AMP DRAW 115 V	STARTUP CURRENT MULTIPLIER	CAPACITOR SIZE (115v)	WEIGHT
	lbs	Kg		in -lbs	h.p.				
VE1/18/ 150	174	79	1.54	0.15	115	1.08	3	25	14
VE1/18/ 450	450	204	5.1	0.23	175	1.8	3	45	27
VE1/18/ 900	908	413	10	0.5	370	4.6	3.5	30+40	54

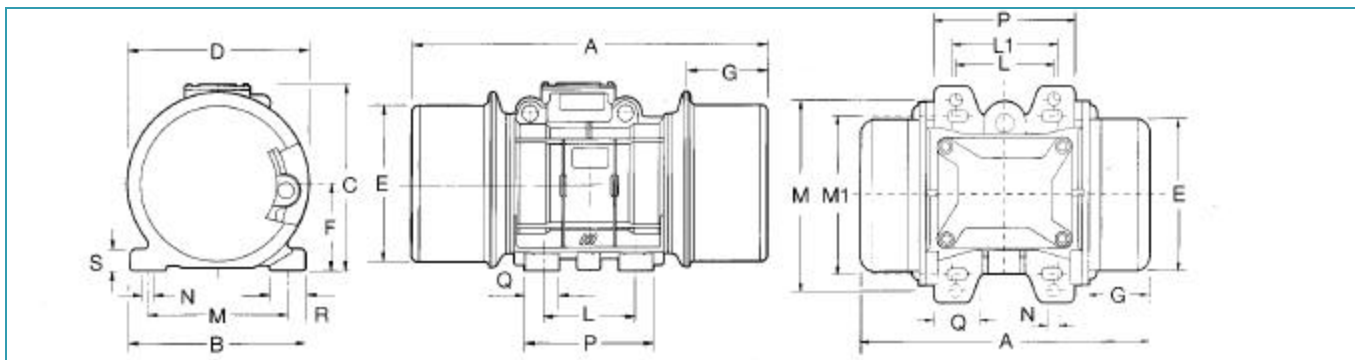

DIMENSIONS

MODEL	A	B	C	D	E	F	G	L	L ₁	M	M ₁	N	P	Q	R	S	BOLT HOLE NBR
VE1/18/150	9.06	5.91	5.71	5.12	4.13	2.36	2.17	2.76	2.44-2.91	5.12	4.17	0.35	3.9	1.18	1.38	0.39	4
VE1/18/450	11.73	6.54	7.28	6.30	5.12	2.95	2.72	3.54	3.54	4.92	5.51	0.51	4.72	1.18	1.57	0.47	4
VE1/18/900	13.78	7.48	8.07	7.36	5.94	3.35	3.35	4.13		5.51		0.51	5.35	1.30	1.57	0.63	4

POWTEK

2500 Pearl Buck Rd - Suite I BRISTOL, PA 19007
 PH: 215-788-2888 FAX: 215-788-2883
 powtekcorp@gmail.com www.powtek.us